

POINT – I

The Particulars
of
its Organization, functions and
duties:

As per Govt. G.O. No. 1483/AC/Resolution dated 29th April 1978:-

The main activities of the Soil Conservation Office: Koraput will be

- i. Soil & Water Conservation.
- ii. Soil Erosion Control Measures
- iii. Prevention of shifting cultivation
- iv. Training of Soil Conservation Personnel.

Soil Conservation Officer, Koraput will be in-charge of the following items work.

- i. Tree plantation including plantation Cashew, Sisal.
- ii. Soil Conservation Demonstration Centre.
- iii. Soil Conservation measures such as Contour Bonding, Nala Bonding, Gully control Structure, Water Harvesting Structure, Stream Bank Erosion Control, Farm Ponds, Silt Retention Dams, Bench Terracing.
- iv. Maintenance of existing plantations and structures already created by Soil Conservation Officers.

ORGANIZATION SET UP OF SOIL CONSERVATION SUB DIVISION OFFICE: KORAPUT

A.S.C.O
Koraput

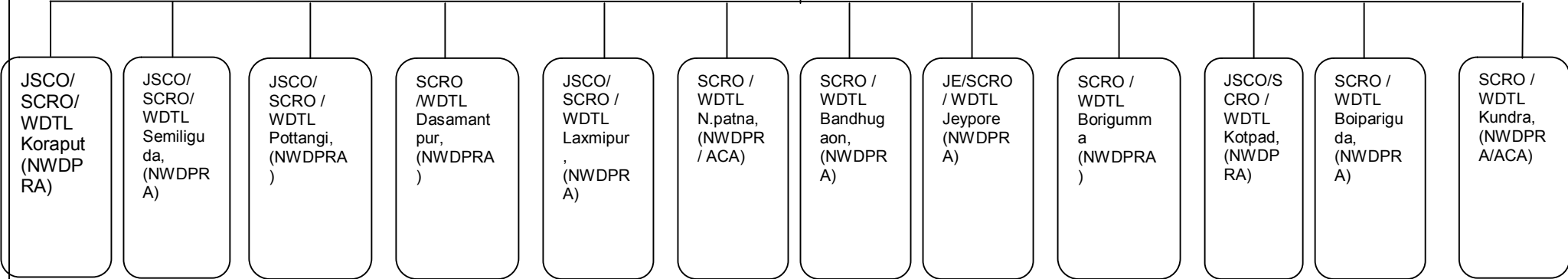

POINT – II

The Power and Duties
Of
its Officers and Employees.

ROLE & RESPONSIBILITIES OF ASST. SOIL CONSERVATION OFFICER

(GROUP – B)

1. He will responsible for conducting survey, planning and preparation of Project Reports and implementation of Soil Conservation and Watershed Projects taken up under different schemes such as NWDPPRA, RVP and other departmental works of State Plan, Non Plan and Central Plan along with the deposit works of DRDAs, CRF, FFW, NREGA, BKBK, BRGF and funds being funded by other agencies for execution of Soil Conservation and related projects.
2. He will exercise the power of D.D.Os and head of office respect of his office as may be delegated by Head of Department.
3. He will responsible for delineation of watersheds, its designing and accord technical sanction of plan and estimates of different watershed activities to the extent as may be delegated from time to time.
4. check measurement of works executed departmentally up to 50%.
5. He is responsible for timely submission of reports and returns to he respective Soil Conservation Officers and higher authorities.
6. Any other duties/responsibilities which may be assigned to him by his higher authorities at the time of need that do not interfere with the essential duties mentioned above.

ROLE AND RESPONSIBILITIES OF THE JUNIOR SOIL CONSERVATION OFFICERS

(GROUP – C)

As per the Resolution “by G.A Department, Government of Orissa vide order NO.15553/Gen dt.26th. June,1984 & Argil. & Co-operation Resolution NO.GE(M)2/86/2650/AC dt.23rd. January,1998), the role and responsibilities of Jr. S.C.O will be as follows.

1. Each Junior Soil Conservation Officer remains in Charge of 10 to 12 Field Assistants, Both Third and fourth Grade Staff such as Assistant, field Asst. Surveyor, Jr. S.C. Asst. Field Man Demonstrator, Bhumirakhyak, Plantation Guard etc, under his control and shall be responsible for effective implementation of Soil Conservation Programme.
2. He guides the Field Asst. and Surveyors in Collection of the basic data of the areas under his range and shall compile the data for his range and submit the same to the Asst. Soil Conservation Officer retaining a copy of the report.
3. He visits all the sections under his jurisdiction and check measures 100% of the works executed in every area and submits the detailed

report to contact the farmers participating in the programmes for giving timely technical guidance to them at least one in a fortnight.

4. His jurisdiction comprises more or less a panchayat samiti depending upon the sub-watershed.
5. He check the Field Assistant whether they are visiting and conducting the meeting on NABARD work and guides the Field Assistants and Farmers in all Technical matters.
6. He checks the field Assistant Diaries and record his observation during this visits, regularly and ensures that those are maintained properly. He also instructs to his staff under his control for making tour programmes to specified areas.
7. He supervises the field work on demonstrations, trials and research plots and guides the field assistants for conducting their demonstrations in both Govt. farm and farmers field too. Also he records the additional yield due to improved practices.
8. In the absence of the Soil conservation Officer/Assistant Soil Conservation Officer, he remains in charge of the officer and controls the day to day official businesses which are of mostly technical in nature.
9. He prepares a perspective Master Plan of Soil Conservation measures for his area including conservation farming trials in farmers field and marketing of the perishable products and system practically implementation of the programme.
10. He conduct tour at least 20days in a month for supervising the work of the subordinate staff and assists them in technical matters in execution the planning. He has to visit the field and check the work before the weekly market day in the locality and conducts meeting for encouraging farmers to take up land development and plantation etc. in their lands.
11. He remains in charge of Soil Conservation Demonstration Centre, Pasture Development Centre and Research Farm, sisal Estates and the duties and responsibilities assigned to him are no way less than those of a farm superintendent.
12. He instructs the Field Assistants in carrying out demonstration of Soil conservation programme in farmer's field and in Soil Conservation Programmes in farmer's field and in Soil Conservation Demonstration Centre.
13. He maintains with him, the details of the fixed programme of Field Assistants and maintains a list of farmers contacted in NABARD works operated in his area.
14. He maintains daily diary of the work done by him and reports the same every month to the Asst. soil Conservation Officer Concerned.
15. He select the applicants for land development, land shaping gully control , irrigation ponds, cashew plantations etc. recommends for getting loan form nationalized Banks and other financing agencies like AFDA, MFAL, TDA, NABARD etc.

16. He investigated the field hazards like saline inundation, sand casting, landslide gully erosion etc. due to heavy storm flood famines and natural calamities.
17. He prepares the soil maps with descriptive roll for interpretation and correlation for utilisation of a particular land for different purpose.
18. He is a sub-disburser and handles cash to a tune of one lakh rupees for labour payment and other contingent expenditure in a year.
29. He checks the plans and estimates, which are of highly technical in nature and prepare the project reports for soil conservation programme.
20. He attends to the interpretation of aerial photographs and land satellite imageries for preparation of watershed planning.
21. He attends the monthly meeting organized by the concerned Asst. soil Conservation Officer and soil Conservation Officer.
22. He assists the Soil Conservation Officers/Asst. Soil Conservation Officers in organizing and conducting field training programme generally conducted at the time of exhibition of a particular programme.
23. He give the requires assistance to the different agencies in conducting research and demonstration programme like yield on cashew, pasture development by product from sisal waste etc.
24. He guides the field assistants in organizing the field days on successful demonstration on conservating farmers, strip cropping land use capability etc.
25. He collects the reports and data from the field Assts. And compiles the same for each watershed-sub-watershed/minimum watershed and submits to higher authority.
26. He attends the Panchayat Samiti meetings and keeps the samiti informed of various soil conservation programmes for that locality.
27. He maintains harmonious relationship with the local officers belonging to the department of co-operation. Revenue, Forest, Irrigation, Panchayat and Commercial Banks and seek their assistance for planning and implementation of soil survey work gully control plantations, soil survey from consolidation and valuations of lands.
28. In the Headquarters, he scrutinize the technical, papers submitted by the S.C. Division Officer, compiles the reports, technical notes and booklets for the use at different levels.
29. He verified the utilization certificates or the farmers for sanction of loans by Banks after checking the work in the field.

30. He participates in village meeting in connection with the NABARD, NREGA, ITDA MFAL AND S.F.D.A. schemes and convinces farmers on the benefit of the programmes.
31. He assists the Asst. soil Conservation Officer in conducting exhibitions and soil conservation Programmes in tribal areas within his jurisdiction.
32. He guides the people to take up counter measures by raising wind breaks against scale, storm, diversion channel for safe disposal of under sizable water flow, spraying of cashew plantation etc.
33. He also collects static on response of people to soil conservation measures like water harvesting structures, contour bonding, terracing conservation farming, amendment of acid alkaline and saline soils from time to time at different parts of the year.
34. He guides the Field Assistants in collecting soil samples for determining the fertility status erosion assessment, soil reaction, feasibility of land for different crops etc.
35. He prepares schemes, technical maps plan from field survey data.
36. He assists in analysis of soil samples and prepares soil fertility report.
37. He attends to the water budgeting and recommendation of cropping pattern in the proposed command areas of Irrigation projects.
38. He prepares land utilization data for different purposes by remote sensing.

ROLE & RESPONSIBILITIES OF THE JUNIOR ENGINEERS IN SOIL CONSERVATION ORGANIZATION

(Group – C)

As per the resolution of G.A. Department, government of Orissa Order No15701/dt.5.9.1986, the role and responsibilities of the Junior engineer as PIA is as follows.

1. Motivate GP to pass resolution to make public contributions,
2. Conduct Participatory Rural appraisal (PRA) exercise.
3. To guide to prepare W.D. plans for each Watershed by the W.C. and U.G.
4. Undertake Community Organization and Training.
5. Providing technical guidance to field staffs.
6. Supervising Watershed Development activities.
7. Manage Project Implementation.
8. Inspect and authenticate the Project accounts.
9. Undertake action research for low cost technologies.
10. Validate and build upon Indigenous technical Knowledge (ITK).
11. Monitor and review the overall Project Implementation.
12. Set up institutional arrangements for post project operation and maintenance further development of assets created.

13. Inform the selection of WDT members and project commencement date to the DRDA.
14. Submit Progress Reports on each W.D.T in every quarter to the DRDA.
15. Conducting review meeting of W.D.T. 3rd of every month.

As per Govt. Order No. SOPE@80/83-226/Ag., dated the 20.8.88 the Jon chart of Following No-Gazetted field staff working under Directorate of Soil Conservation, Orissa is as follows:

1. Soil Conservation Assistant (Group – C)
2. Soil Conservation Technical Assistant (Group – C)
3. Soil Conservation Sectional Officer (Group – C)
4. Junior Soil Conservation Assistant (Group – C)
5. Grafter (Group – C)
6. Amin (Group – C)
7. Field Man (Group – C)
8. Laboratory Attendant (Group – C)
9. Draughtsman (Group – C)
10. Tracer(Group – C)

Soil Conservation Assistant

The Soil Conservation Assistants working under Soil Conservation Directorate belongs to Class – III non-gazetted field staff. The main duties of these field officers include:-

1. Watershed Planning and execution of soil & Water Conservation measures such as contour bunding, land development, terracing structures such as WHS, G.C. Diversion bunds, spillways, apart from planning and execution they are also responsible for utilization of Soil and water resources for the development of the area through extension and training programme.
2. Soil Survey and field investigation, field experiment and analysis of Soil & Water samples collected from field and streams.
3. Imparting training to S.C.S.O.s Jr. S.C Asst., F.M.D and other staff working for the watershed development programme along with the local beneficiaries involved in the Development programme.
4. They will conduct the special survey of the damages caused due to natural calamities such as flood and wind and casting, land slide etc. and prepare the estimate for repair and report to the Soil Conservation Officer/A.S.C.O. for further action by the Government.
5. They will motivate farmers and the other local beneficiaries to take up the low cost soil conservation measures through extension

programmes such as group discussions, meetings exhibition, demonstration etc. in the locality/watershed.

6. He may function as watershed team leader in absence of J.S.C.O. and will execute the Soil Conservation works in the watershed.
7. He will prepare the plan and estimate of both vegetative and engineering structures with consultation/help of the S.C.S.O., J.S.C.A. and other staff working in the locality/watershed and submit to the A.S.C.O. for necessary scrutiny and action.
8. They will obtain the technical guidance and instruction from his A.S.C.O., S.C.O. or through training as the case may be and will impart the same to the staffs down below. But they will be totally responsible for proper supervision and implementation of the work in the field.
9. He will submit the reports & returns to the Soil Conservation Officer/A.S.C.O concerned to his work in time.
10. He will make 100% check measurements of the Soil Conservation works (both vegetative & engineering structures) executed under his jurisdiction.
11. He is to prepare the Project Control Register and will maintain personally.
12. The Soil Conservation Assistants will prepare and the plantation journal and the calendar of operation of works.
13. They will ensure the Govt. by furnishing the necessary certificate on the body of the vouchers, muster roll, Contract labour works/forms.
14. They will maintain stock & store register and verify the stock before signing the stock entry certificate.
15. They will ensure the Govt. by furnishing the necessary certificate on the body of the vouchers, muster roll, contract labour forms etc. before and after the disbursement of the amount due. If any thing wrong is detected, he should immediately bring it to the notice of the A.S.C.O. or immediate authority for necessary action.
16. He will maintain the Cash Book, Stock Register, Plan and Estimate Register, Field diary, Field Instruction Books, Personal Ledger, Issue and Receive Register etc. Keep them in safe custody. He will be responsible for stolen/damage of any of the above records.
17. He will keep the money receipt book in safe custody and maintain.
18. Due to financial involvement in his job, he will produce the records and registers as per the requisition by the ASCO/SCO, Govt. Auditors, A.G Auditors and will furnish the necessary compliance if required.
19. He will discharge the duty in technical Section when posted in the Headquarters office of ASCO/SCO/ D.S.O(O) or equivalent posts.

20. In view of the dearth of staff or reduction of staff due to austerity measures down below his cadre they will be responsible for execution of field works, range establishment submission of range reports, returns etc. to the ASCO.
21. They will attend to any other work assigned to them by the higher authorities in exigency of public service.

Soil Conservation Technical Assistant

The Soil Conservation Technical Assistant are the Class – III non-Gazetted field staff. The S.C.T.A. will work in the field as well as in the office of the General Executing and Survey Wing of the Organization. The duty/functions of the S.C.T.A. are-

1. In the office they are attached to the technical cell and are to assist the A.S.C.O as the case may be.
2. They are responsible for preparation of all reports and returns of technical Engineering.
3. Checking of plan and estimates of all soil conservation works both vegetative and structural.
4. Assisting the J.S.C.O/A.S.C.O preparation of the schemes/action plans.
5. Compilation of progress reports in respect of different schemes operation in the sub-division/division for approval of the HEAD OF Officer.
6. All correspondences relating of execution of S.C. works.
7. In the Training Institute, they are to impart practical training to the trainees.
8. In the Laboratory, they may be engaged for analysis of the samples as per the instruction of the R.O./A.S.C.O.
9. In the survey wing, they are to soil survey work.
10. They are to analyze the data collected on the field survey in consultation with the team leader (JSCO/ASCO and will prepare the preliminary draft reports.
11. In absence of the camp leader (JSCO) the SCTA will function as camp leaders with all functions of camp leader.
12. Files relating to approval of tour programme and tour diary of technical staff and the correspondence there of.

13. Any other work assigned to him as and when required by the higher authority in exigency of public service.

Soil Conservation Section Officer

The Soil Conservation Sectional Officers are the Class – III Non-Gazetted Field staff. They are mostly engaged in executing sub-divisions. However, in the Division Office, Training Institutes, Survey Wing such officers are also engaged depending on the need. The main duties or job of the S.C.S.Os are as follows.

1. They are to survey the locality and to locate the problem areas needing conservation measures.
2. They are to assist the J.S.C.O./J.E./S.C.Asst. in surveying the watershed/locality for preparation of W.P R. or Action Plan.
3. Collection of basic data (Socio economic data climatologically data, Land records, human and animal resources etc.) for preparation of project report/action plan etc.
4. At the grass-root level they to impart the low cost technical know-how to the beneficiaries of the watershed locality through extension method.
5. Explain the utility and benefits of the S.C. measures taken by the Department so as to take proper care of the assets created by the organization as well as to promote the low cost structures to be done by the farmers himself at their own cost.
6. They are to collect laborers and engage them in doing the S.C. works both vegetative and structural such as plantation. G.C, WHS., P.C. , Veg. contour bunds, diversion weir channels, land reclamation, pasture development etc., as per the instruction of the J.S.C.O/S.C. Asst/J.E
7. Assisting the J.S.C.O./J.E./S.C.Asst. for preparation of plan and estimate of the S.C works to be taken.
8. Maintain the muster roll.
9. He is to physically present in the field and execute the S.C. works assigned to him through the labourers engaged as per the instruction/guidance of the J.S.C.O/J.E./S.C.Asst.
10. He is to identify the labourers at the time of payment and the necessary certificate to that effect is to be furnished by him under his signature and date.
11. He is the record the works done in the Measurement book with his signature and date, which is to be check measured by his authorized authority.
12. He is to receive the store materials required for the S.C. work and to furnish the utilization certificate on the body of the voucher with his signature and date.

13. When attached to office, he is to assist the officer in charge technical cell in preparation of reports returns of office. In absence of any technical officer he may directly work under the guidance of the Head of office.
14. In the Laboratory he may be engaged to assist in analysis of samples both soil and water as the case may be.
15. In the training institute they are engaged to assist in practical training of the trainees or as per the instruction of the Principal or the course co-ordinator.
16. Any other works as and when assigned by the higher authority in exigency of public interest.

Junior Soil Conservation Assistance:

The junior soil conservation Assistants are the Class – III Non-Gazetted Field staff. They are mostly engaged in executing sub-divisions. However, in the division office Training institutes, Survey wing such officers are also engaged depending on the need. The main duties or job of the J.S.C.A.s are as follows:-

1. They are to survey the locality and to locate the problem areas needing conservation measures.
2. They are to assist the J.S.C.O./J.E./S.C. Asst. in surveying the watershed/locality for preparation of W.P.R. or action plan.
3. Collection of basic data (Socio economic data climatologically data, Land records, human and animal resource etc.) for preparation of project report/action plan etc.
4. At the grass root level they are to impart the low cost technical know how to the beneficiaries of the watershed locality through extension method.
5. Explain the utility and benefits of the S.C measures taken by the Deptt. So as to take proper care of the assets created by the organization as well as to promote the low cost structures to be done by the farmers himself at their own cost.
6. They are to collect labourers and engage them in doing the S.C works both vegetative and structural such as platform, G.C., W.H.S. P.C.Veg contour bunds, diversion weir channels, land reclamation, pasture development etc., as per the instruction of the J.S.C.O./S.C. Asst./J.E
7. Assisting the J.S.C.O./J.E./S.C.Asst. for preparation of plan and estimate of the S.C works to be taken.
8. Maintain the muster roll.

9. He is to physically present in the field and execute the S.C. works assigned to him through the labourers engaged as per the instruction/guidance of the J.S.C.O/J.E./S.C.Asst.
10. He is to identify the labourers at the time of payment and the necessary certificate to that effect is to be furnished by him under his signature and date.
11. He is to record the works done in the Measurement book with his signature and date, which is to be checked measured by his authorized authority.
12. He is to receive the store materials required for the S.C. work and to furnish the utilization certificate on the body of the voucher with his signature and date.
13. When attached to office, he is to assist the officer in charge technical cell in preparation of reports returns of office. In absence of any technical officer he may directly work under the guidance of the Head of office.
14. In the Laboratory he may be engaged to assist in analysis of samples both soil and water as the case may be.
15. In the training institute they are engaged to assist in practical training of the trainees or as per the instruction of the Principal or the course co-ordinator.
16. Any other works as and when assigned by the higher authority in exigency of public interest.

Amin

The Amin are Class – III Non-Gazetted field staff and are mainly attached to the Soil Survey wing of the Soil Conservation Organization. The main duties of the Amins are-

1. Collection and tracing of village maps and other maps.
2. Passing the area on the maps
3. Mosaic of maps
4. Reduction and enlargement of maps by use of pantograph or through photo enlargement or reduction.
5. Delineation of unit boundary, identification of problem areas like, water logged, saline affected area, deforested area and special identification are line paddy area etc.
6. Collection of Soil and water samples for laboratory analysis.
7. They will maintain the muster roll and contract labour vouchers.
8. In field they will collect the labourers and will supervise the fieldwork as those of the J.S.C.A. As to survey the land and soil etc.
9. They will assist the J.S.C.A/S.C.T.A. to survey the land and soil etc.

10. Identification of Soil Conservation measures needed in a watershed and noting them on the cadastral maps.
11. They will attend to any other works assigned to him by the higher authorities in exigency of public service.

Field Man Demonstrator:

The Field Man Demonstrator are the Class – III Non-Gazetted field employees of the Soil Conservation Organisation. The main duties of the F.M.D.s are as follows.

1. They are to physically work in the field and demonstrate beneficiaries of the locality the utility and the benefits of the Soil Conservation measures taken in the field.
2. They are to collect the labourers and engage them and supervise the work in the field as per the instruction of the J.S.C.O./S.C.Asst.
3. Any other work assigned to them by the higher authorities in public interest.

POINT – III

The Procedure followed in the decision-making process, including channels of Supervision and accountability.

After receipt of the letters from different quarters the same are being distributed between different sections through the Head Clerk after the letters are marked and entered in the Diary Register in the name of the concerned Assistant, he/she being the custodian of the files puts up the letters in the files through the Head Clerk. The files are submitted to the Asst. Soil Conservation Officer through the Head Clerk to take the final decision for disposal of the letters.

POINT – IV

The norms set by it for the discharge of its functions.

**GOVERNMENT OF ORISSA
AGRICULTURE DEPARTMENT**

OFFICE ORDER

No.SC(CP) 114/2007 21148 /Ag., Bhubaneswar, Dated 8th July,2008

Sub: Delegation of powers to the Field officers under Soil Conservation Organization for technical sanction and Administrative approval of plan and estimate of Soil Conservation Projects.

The question of revision of powers delegated for technical sanction and administrative approval to the officers of Soil Conservation organization was under consideration of Govt. for some time past. Ater careful consideration Govt. have been pleased to delegate powers to the officers under Soil Conservation Organization for technical sanction and administration approval of plan and estimate of Soil Conservation Projects as per below give details.

Sl. No.	Designation of Officer	Technical Sanction	Administrative approval
1.	Junior Soil Conservation Officer, (JSCO)	Up to 0.25 Lakh	
2.	Asst. Soil Conservation Officer, (ASCO)	Up to 2.00 Lakhs	Up to 0.25 Lakhs
3.	Soil Conservation Officer (SCO)	Up to 5.00 Lakhs	Up to 2.00 Lakhs
4.	Joint Director, Soil Conservation (JDSC)	Up to 10.00 Lakhs	Up to 5.00 Lakhs
5.	Director, Soil Conservation, Orissa(DSC (O))	Nil	More then 5.00 Lakhs
6.	Assistant engineer (Soil Conservation)	Up to 2.75 Lakhs (For WHS/ DW)	
7.	Executive Engineer (Soil Conservation)	Up to 5.00 Lakhs (For WHS/ DW)	

2. This order supersedes all previous orders made on the subject.
3. Any officers mentioned above, while giving technical sanction for a particular work with in his powers, the Adminstrative approval will be accorded by the next higher Authority/ Officer with in the powers delegated to him.
4. No split of the work will be allowed.
5. The above delegation of powers will come into force with immediate effect.
6. The Principal Accountant General, Orissa is being informed.

Sd/-
Commissioner-Cum-secretary to
Government.

GOVERNMENT OF ORISSA
Agriculture And Cooperation Department

No.SC(M)128/86 4775/g. Bhubaneswar Dated,

From:

Shri G. Sahoo,
Under Secretary to Government.

To

The Director, Soil Conservation, Orissa, Bhubaneswar.

Sub: Delegation of power to the officer of the Soil Conservation Organisation.

Ref: Your letter no.17749/SC., dated 19.11.

Sir,

In partial modification of the G.O No.15545/Ag, dated 7.5.1985 delegating power to Director, Soil Conservation, Orissa and other officers working under Directorate of Soil Conservation for according administrative approval and technical sanction for different Soil Conservation works executed by the Soil Conservation Organisation, I am directed to say that the Governor has further been pleased delegate the following enhanced powers to the officers indicated below.

Administrative Approval

Sl. No	Name of the Officer	Item of work	Existing powers to accord administrative approval	Enhanced powers to accord administrative approval
1	Soil Conservation Officer	Water Harvesting Structure	Rs.70000/-	Rs.1,00,000/-

Technical Sanction

Sl. No	Name of the Officer	Item of work	Existing powers to accord administrative approval	Enhanced powers to accord administrative approval
1	Executive Engineer	Water Harvesting Structure	Rs.70000/-	Rs.1,00,000/-
2.	Soil Conservation Officer	Water Harvesting Structure	Rs.50000/-	Rs.1,00,000/-
3.	Asst. Soil Conservation Officer	Water Harvesting Structure	Rs.20,000	Rs.40,000
4.	Asst. Engineer	Water Harvesting Structure	Rs.20,000	Rs.50,000

2. Delegation of power made in favour of all officers in the G.O referred to above except as stated in Para.1 above remain unchanged.

The Accountant General , Orissa is being informed.

Yours faithfully,

Sd/-

Under Secretary to Govt.

Government of Orissa
Agriculture and Co-operation Department

No.SC(S)37/85/15546/Ag.Dated,7th May, 1985

From

Shri H.K. Das,OSS
Under Secretary to Govt.

To

The Director, Soil Conservation, Orissa

Sub: Delegation of powers to the officers of the Soil Conservation Organisation.

Sir,

In suppression of this Deptt. G.O No.4875/AC, Dt.27.2.73 on the subject mentioned above, I am directed to say that with a view to expedite execution of Soil Conservation works, Governor has been pleased to decide to delegate the following powers for according administrative approval and technical sanction to the different categories of officers working in the Soil Conservation Organisation.

Sl. No.	Name of the Officers	Item of Work		Powers to accord administrative approval	Powers to account technical sanction.
1.	Director of Soil Conservation, Orissa	(i)	Water Harvesting Structure	Rs.2,00,000/-	-
		(ii)	Land Reclamation	Rs.1,00,000/-	Rs.1,00,000/-
		(iii)	Gully control/ Farm pond	Rs.80,000/-	Rs. 50,000/-
		(iv)	Counter bonding	Rs.75,000/-	Rs. 50,000/-
		(v)	Terracing	Rs.1,00,000/-	Rs. 60,000/-
		(vi)	Field bonding fencing & trench digging	Rs.60,000/-	Rs. 60,000/-
		(vii)	Plantation including land preparation & cultural operation	Rs.1,00,000/-	Rs. 75,000/-
2.	Joint Director of Agriculture (Engg)		Water Harvesting Structures	-	Rs.2,00,000
3.	Soil Conservation Officer	(i)	Water Harvesting Structure	Rs.70,000/-	Rs. 50,000/-
		(ii)	Land	Rs.40,000/-	Rs.40,000/-

			Reclamation		
		(iii)	Gully control/ Farm pond	Rs.40,000/-	Rs.40,000/-
		(iv)	Counter bonding	Rs.30,000/-	Rs. 20,000/-
		(v)	Terracing	Rs.40,000/-	Rs. 20,000/-
		(vi)	Field bonding & trench digging	Rs.20,000/-	Rs. 15,000/-
		(vii)	Plantation including land preparation & cultural operation	Rs.40,000/-	Rs.40,000/-
		(viii)	Steam Bank Erosion control	Rs.20,000/-	Rs.20,000/-
4.	Executive Engineer (Soil Conservation)	(i)	Water Harvesting Structure	-	Rs. 70,000/-
		(ii)	Gully control/ Farm pond	-	Rs.25,000/-
		(vi)	Field bonding & trench digging	-	Rs. 15,000/-
5.	Asst.Soil Conservation Officer	(i)	Water Harvesting Structure	Rs.20,000/-	Rs. 20,000/-
		(ii)	Land Reclamation	Rs.10,000/-	Rs.8,000/-
		(iii)	Gully control/ Farm pond	Rs.20,000/-	Rs.10,000/-
		(iv)	Counter bonding	Rs.10,000/-	Rs. 7,000/-
		(v)	Terracing	Rs.20,000/-	Rs. 8,000/-
		(vi)	Field bonding & trench digging	Rs.8,000/-	Rs. 4,000/-
		(vii)	Plantation including land preparation & cultural operation	Rs.10,000/-	Rs.10,000/-
		(viii)	Steam Bank Erosion control	Rs.10,000/-	Rs.10,000/-
6.	Asst.Engineer (Soil Conservation)	(i)	Water Harvesting Structure	-	Rs. 20,000/-
		(ii)	Land Reclamation		Rs.10,000/-
		(iii)	Gully control/ Farm pond		Rs.10,000/-
		(iv)	Counter		Rs. 5,000/-

			bonding		
		(v)	Terracing		Rs. 10,000/-
		(vi)	Field bonding fencing & trench digging		Rs. 4,000/-
6.	Soil Conservation Asst./Sr. Soil Conservation Asst. (Engg. Diploma holders only)	(i)	Water Harvesting Structure	-	Rs. 3,000/-
		(ii)	Land Reclamation		Rs.3,000/-
		(iii)	Gully control/ Farm pond		Rs.2,500/-
		(iv)	Counter bonding		Rs. 2,500/-
		(v)	Terracing		Rs. 2,500/-
		(vi)	Field bonding fencing & trench digging		Rs. 1,500/-

1. The Accountant General , Orissa is being informed.

Yours faithfully,
Sd/-
Under Secretary to Govt.

**Government of Orissa
Agriculture Department**

No.SC(Misc)3491-1659 dated, Bhubaneswar the, 17.1.92

From

Meena Gupta,
Secretary to Government.

To

The Director, Soil Conservation, Orissa, Bhubaneswar.

Sir,

With a view to create additional irrigation potential in 5 lakh ha. during the 7th plan period by construction of WHS Government had created some additional posts in the Agricultural Engineering Organisation and the manner of their deployment was also outlined in G.O. No41968 dated 8.12.86. These posts were primarily created in connection with construction of WHS and in G.O BI 15546/AG., dated 7.5.85 and No.4475/dated 16.2.87 Government has also delegated powers in favour of Director, Soil Conservation, Soil Conservation Officer, Executive Engineer and Assistant Engineer to accord administrative approval and technical sanction. It has now come to the notice of the Government that although these posts were created for construction of WHS the services of these engineering personnel are not being utilized fully. This matter was discussed in details in a High Level Meeting under the Chairmanship of the Minister, agriculture on 28.11.91 and the census of opinion in the meeting was that the services of the engineering personnel should be utilised for the purpose for which they were created accordingly Government after careful consideration of the above facts have decide that since the designing and construct of WHS involves engineering know hereafter the construction of WHS should be exclusively entrusted to the Agricultural Engineers working in the Soil Conservation Organisation. The Executive Engineers, Asst. Engineers and Junior Engineers will design accord technical sanction and execute the construction of WHS. The power delegated in G.O. No.15546/AC., dated 7.5.85 and No.4775 dated 16.2.87 for according technical sanction in favour of Soil Conservation Asst. Soil Conservation Officer and Soil Conservation Assistant/Senior Soil Conservation Assistant (now re-designated JSCO) is hereby withdrawn. The Director, Soil Conservation Officer and Soil Conservation Officer, Asst. Soil Conservation Officer will however, continue to accord administrative approval a laid down in the aforesaid Government Orders.

It is further been decided to distribute the districts among the Executive Engineers keeping in view the work load and the number of Agriculture Asst. Soil Conservation should issue suitable instructions to the Soil Conservation Officer attach the required number of minister staff to the Executive Engineers for the effective functioning.

Yours faithfully,
Sd/-
Secretary to Government.

POINT – V

The Rules, Regulations, Instructions, Manuals and Records, held by it or under its control or used by its employees for discharging its functions:

- a. The Rules, Regulations, Instructions etc. as issued by Government from time-to-time and reflected in Orissa Service Code, Treasury Code, OGFR, Record Manual, CCA Rules and Scheme Guide line (as below) etc. held by this Directorate for control and used by its employees for discharging its functions.
- b. WARSA – JANA SAHABHAGITA guidelines for National Watershed Development Project for Rain fed Areas (NWDPR) published by Govt. of India, Ministry of Agriculture, Department of Agriculture & Co-operation.
- c. Updated Guidelines for Centrally Sponsored Scheme of Soil Conservation for Enhancing Productivity of Degraded Lands in the Catchments of River Valley Projects and Flood Prone Rivers Published by Govt. of India, Ministry of Agriculture, Department of Agriculture & Co-operation, Natural Resource Management Division, Shastri Bhawan, New Delhi.

POINT – VI

A statement of the Categories of documents that are held by it or under its control:

Sl. No	Name of the Section	Deals with	Records and Documents Kept for reference
01	Confidential Section	CCRS of staff and ACR of Group "B" & "C" Officers.	<ol style="list-style-type: none"> 1. Correspondence on CCR. 2. CCR Register
02.	Establishment.	Non-Gazetted Establishment	<ol style="list-style-type: none"> 1. All personal case file of the Non-Gazetted staff and maintenance of Original and duplicate Service Books of staff. 2. Transfer and posting of staff, Gradation list of Non-Gazetted staff. 3. Misc. File 4. Pension case file of all retire/expired employees. 5. Allotment of Departmental quarters file and collection of house rent register. 6. Drawl of Bills (Salary, T.E & RCM). 7. GPF sanction order file 8. HUDCO loan register. 9. Service Book Register of Non-Gazetted staff. 10. Preparation of Budgets. 11. Correspondence on Assembly question.
03.	Issue and Despatch Section	Issue and Despatch	<ol style="list-style-type: none"> 1. Issue, Receive and Despatch registers. 2. Peon Book. 3. Service Postage Stamps register.
04..	Technical , Stock & Store	Dealing all watersheds & stock & store	<ol style="list-style-type: none"> 1. Consumable and Dead stock register, 2. Log Book and Spare Parts register of Govt. jeep 3. Stationary and forms register, 4. Correspondence on Stock and store file. 5. Correspondence on Jeep. 6. Correspondence on Forms

05. Technical

& Stationary file.

7. Correspondence file on watershed of NWDPRRA, RVP, ACA, IWDP.
1. Correspondence on plantation under all scheme.
2. Sanction of plan and estimates.
3. Correspondence on meeting.
4. Correspondence on Public allegation and grievances.
5. M.P.R. files under all scheme.
6. Correspondence on building and engineering structures.
7. Correspondence on Assembly question.

05. Accounts

Cash and Accounts

1. Allotment and expenditure.
2. Cash and maintenance of cash book.
3. Compliance of Inspection Reports i.e. IR, IAR, C & AG report and draft paras.
4. Preparation of Budget.
5. Preparation of Contingent Bills.
6. Advance and submission of U.C
7. Correspondences on Schemes.

POINT – VII

The Particulars of any arrangement that exists for consultation with, or representation by the members of the public in relation to the formulation of its policy or implementation thereof.

The scheme National Watershed Development Project for Rainfed Areas (NWDPR) a centrally sponsored scheme borne under Macro Management of Agriculture (Work Plan is being implemented through the watershed committees. All the adult members in area of operation of the scheme i.e. watershed are the members of watershed association which is registered under Society Registration Act,1860. The representation of Watershed Association are nominated to for a watershed committee. Under this Sub-Division coming in Koraput Revenue districts as WARSA – JANASAHABHAGITA guide lines. 9 Nos. of watershed are continuing under this Sub-Division with people's participation.

POINT – VIII

A statement of the Boards, Councils, Committees and other bodies consisting of two or more persons constituted as its part or advise, and as to whether meeting of those boards, councils, committees and other bodies are open to the public, or the minutes of such meetings are accessible for public

*** Not applicable to Directorate of Soil conservation ***

And also to ASST. SOIL CONSERVATION DIVISION , KORAPUT

POINT – IX

A directory of its officers and
employees:

Sl. No.	Employees Name	Designation	Address with Phone No.
01.	Sri Dayanidhi Bagh	A.S.C.O.	O/o Asst. Soil Conservation Officer Po/Dist:Koraput (Orissa) Pin:764 020 ☎ 06852-250114
02.	Sri Narasingh Kurami	Head Clerk	O/o Asst. Soil Conservation Officer Po/Dist:Koraput (Orissa) Pin:764 020 ☎ 06852-250114 Cell: 9939834523
03.	Sri Jagannath Mishra	Sr. Clerk	O/o Asst. Soil Conservation Officer Po/Dist:Koraput (Orissa) Pin:764 020 Physically working at Tilibgash Cell: 9437784904
04.	Sri Surendra Natha Swain (Under deputation to AE (SC), Titilagar.	Jr. Clerk	O/o Asst. Soil Conservation Officer Po/Dist:Koraput (Orissa) Pin:764 020
05.	Sri Niradananda Patro	Jr.Clerk	O/o Asst. Soil Conservation Officer Po/Dist:Koraput (Orissa) Pin:764 020 ☎ 06852-250114
06.	Sri Kumuda Chandra Patro	J.S.C.O	S.C.R.O.–CUM–WDTL, Semliguda & I/C S.C.R.O,Pottangi At/Po: Semiliguda Dist: Koraput Cell: 9437077686 ☎ 06852-251686
07.	Sri Rabindra Kumar Sahu	J.S.C.O	S.C.R.O.–CUM–WDTL, Laxmipur & I/c SCRO cum WDTL, Koraput At/Po: Koraput Dist: Koraput ☎ 06852-250074 Cell: 9437820905
08.	Sri K.Dasarathi Ram	J.S.C.O.	Deployed to P.D., D.R.D.A. Rayagada.
09.	Sri Rameswar Majhi	J.S.C.O	SCRO, Kotpad At/Po: Kotpad Dist: Koraput Cell: 9437459263
10.	Sri Madhab Chandra Das	S.C.Asst.	S.C.R.O.–CUM–WDTL, Kundra & I/c S.C.R.O.– CUM–WDTL, Boipariguda At/Po: Kundra

			Dist: Koraput Cell: 9438376026
11.	Sri Minaketan Oram	S.C. Asst.	O/o ASCO, Koraput Dist: Koraput ☎ 06855-250114 Cell: 9438711660
12.	Sri Subash Chandra Prusty	S.C. Asst.	SCRO, Borigumma At/Po: Borigumma Dist: Koraput ☎ 06852-250114 Cell: 9437818896
13.	Sri K.C.Patra	J.S.C.O.	Additional charges for SCRO WDTL, Pottangi At/Po: Semiliguda Dist: Koraput Cell: 9437077686
14.	Sri Jayasen Murmu	Jr. Engineer	S.C.R.O. Jeypore, At/Po: Jeypore Dist: Koraput Cell: 9437913513
15.	Sri Harihar Sahu	S.C.T.A.	O/o- ASCO, Koraput At/Po/Dist -: Koraput ☎ 06852-250114 Cell: 9437721294
16	Sri Bipini Bihari Panda	S.C Tech. Asst	WDTL, Jeypore At/Po: Jeypore Dist: Koraput ☎ 06854-205114 Cell: 9437351058
17.	Sri Arjuna Chandra Bhotra	S.C. S.O.	C/o S.C.R.O.-CUM-WDTL, Dashmantpur At/Po: Podagada Dist: Koraput ☎ 06852-252307 Cell: 9437337898
18.	Sri Udayanatha Mahankuda	S.C. S.O.	C/o S.C.R.O.-CUM-WDTL, Boipariguda At/Po: Boipariguda Dist: Koraput ☎ 06854-249563
19.	Sri Purusottam Mohanto	S.C. S.O.	C/o S.C.R.O., Jeypore At/Po: Jeypore Dist: Koraput Mob-9437862333
20.	Sri Satish Pattnaik	S.C. S.O.	C/o S.C.R.O.-CUM- WDTL, Koraput At/Po/Dist: Koraput Mob-9437458571
21.	Sri Siba Ram Sahu	S.C. S.O.	C/o S.C.R.O.-CUM- WDTL, Koraput At/Po/Dist: Koraput ☎ 06852-250333

22.	Sri Durjyadhana Sahu	S.C. S.O.	C/o SCRO-Cum WDTL Kakriguma At/Po- Kakriguma Dist- Koraput
23.	Sri Khirabdhhi Singh	S.C. S.O.	C/o S.C.R.O. Boipariguda At/Po: Boipariguda Dist: Koraput
24.	Sri Purna Chandra Nayak	S.C. S.O.	C/o SCRO-Cum WDTL, N. Patna & Bandhugaon At/Po: Narayanapatna Dist: Koraput Mob- 9437385746
25.	Sri Ram Prasad Shroff	S.C. S.O.	C/o S.C.R.O.–CUM– WDTL, Koraput At/Po/Dist: Koraput Cell: 9437235702
26.	Sri Prasant Kumar Patro	S.C. S.O	C/o S.C.R.O.–CUM– WDTL, Koraput At/Po/Dist: Koraput Mob- 9437204375
27.	Sri Rabindra Kumar Mallick	S.C. S.O	C/o S.C.R.O.–CUM–WDTL, Laxmipur At/Po/Dist: Koraput
28.	Sri Laxmi Kanta Behera	S.C. S.O	C/o WDTL, Koraput At/Po: Koraput Dist: Koraput
29.	Sri Ramesh Chandra Sahoo	S.C. S.O	C/o SCRO-Cum WDTL Kakriguma At/Po: Kakriguma Dist: Koraput Mob- 9438637695
30.	Sri Surendra Behera	J.S.C.A	C/o S.C.R.O.–CUM–WDTL, Laxmipur At/Po/Dist: Koraput ☎ 06855-266560
31.	Sri Nityananda Pothal	J.S.C.A	C/o S.C.R.O.–CUM– WDTL, Koraput At/Po/Dist: Koraput ☎ 06852-251237 Mob- 9437746029
32.	Sri Kailash Chandra Patro	J.S.C.A	C/o SCRO-Cum-WDTL Narayanpatna At/Po: Narayanpatna Dist: Koraput Mob- 9438538389
33.	Sri Bidya Dhara Dash	J.S.C.A	C/o S.C.R.O.–CUM–WDTL, Laxmipur At/Po/Dist: Koraput Cell: 9437164562
34.	Sri Rajendra Kumar Bal	J.S.C.A	C/o SCRO-Cum-WDTL At/Po: Pottangi Dist: Koraput

35	Sri Manoj Kumar Panda	J.S.C.A	C/oS.C.R.O.–CUM–WDTL, Pottangi At/Po:Pottangi Dist: Koraput Cell: 9438692814
36.	Sri Gangadhar Behera	J.S.C.A	O/o Soil Conservation Officer, Koraput
37.	Sri Jayarama Rout	J.S.C.A	C/oS.C.R.O.–CUM–WDTL, Kundra At/Po:Kundra Dist: Koraput ☎ 06854-248834
38.	Sri Shyam Narayan Ram	J.S.C.A	C/oS.C.R.O.Borigumma At/Po:Borigumma Dist: Koraput Mob- 9437467348
39.	Sri Pradeep Kumar Lima	J.S.C.A	C/oS.C.R.O.–CUM–WDTL, Narayanpatna At/Po:Narayanpatna Dist: Koraput Cell: 9437643891
40.	Sri Ganapati Sethi	J.S.C.A	C/oS.C.R.O.–CUM–WDTL, Borigumma At/Po:Borigumma Dist: Koraput ☎ 06860-280363 Cell: 9437435016
41.	Sri B.Dileswar Rao	J.S.C.A	O/o Asst. Soil Conservation Officer Po/Dist:Koraput (Orissa) Pin:764 020 ☎ 06852-250232
42.	Sri Bighnaraj Jena	J.S.C.A	C/oS.C.R.O.–CUM–WDTL, Boipariguda At/Po:Boipariguda Dist: Koraput
43.	Sri Raj Kishore Bisoyi	J.S.C.A	C/oS.C.R.O.–CUM–WDTL, Semiliguda At/Po:Semliguda Dist: Koraput
44.	Sri Narayan Chandra Majhi	J.S.C.A	C/o S.C.R.O., Boriguma At/po: Boriguma Cell: 9437373691
45.	Sri Hemanta Ku. Satpathy	J.S.C.A	C/oS.C.R.O.–CUM–WDTL, Bandhugaon At/Po:Bandhugaon Dist: Koraput Mob- 9937983052
46.	Sri B. Nageswar Rao	J.S.C.A	C/oS.C.R.O.–CUM–WDTL, Semiliguda At/Po:Semiliguda Dist: Koraput ☎ 06853-225175

47.	Sri Hadubandhu Sabar	J.S.C.A	C/oS.C.R.O.–CUM–WDTL, Dashmantpur At/Po:Dashmantpur Dist: Koraput
48.	Sri Rajendra Mohanty	J.S.C.A	C/oS.C.R.O.–CUM–WDTL, Boipariguda At/Po:Boipariguda Dist: Koraput ☎ 06854-241192 Cell: 9437234327
49.	Sri Jaya Tangulu	J.S.C.A	C/o SCRO, Kotpad At/Po:Kotpad Dist: Koraput ☎ 06860-283117 Cell: 9437433359
50.	Sri Brundaban Mohankuda	J.S.C.A	C/o SCRO, Kotpad At/Po:Kotpad Dist: Koraput
51.	Sri Sameer Kumar Pradhan	J.S.C.A	C/oS.C.R.O.–CUM–WDTL, Kundra At/Po:Kundra Dist: Koraput Cell: 06854-248917
52.	Sri Dilip Kumar Padhi	J.S.C.A	C/oS.C.R.O.–CUM–WDTL, Bandhugaon At/Po:Bandhugaon Dist: Koraput Mob-
53.	Sri Madhu Hontal	J.S.C.A	C/oS.C.R.O.–CUM–WDTL, Semiliguda At/Po:Semliguda Dist: Koraput Mob- 9438475532
54.	Sri Jagannath Tripathy	J.S.C.A	C/oS.C.R.O.–CUM–WDTL, Jeypore At/Po:Jeypore Dist: Koraput Cell: 9437215347
55.	Smt. Lilimani Singh	J.S.C.A	O/o Asst. Soil Conservation Officer Po/Dist:Koraput (Orissa) Pin:764 020 ☎ 06852-250295
56.	Sri Kailash Chandra Rath	J.S.C.A	C/o SCRO-Cum-WDTL Kakiriguma At/Po: Kakiriguma Dist: Koraput Cell:
57.	Sri Narendra Nath Naik	S.C.S.O	C/o SCRO-Cum-WDTL, Semiliguda At/Po: Semiliguda Dist: Koraput Mob- 9438066655

58.	Sri Surendra Nath Panda	J.S.C.A	C/oS.C.R.O., Borigumma At/Po:Boipariguda Dist: Koraput Cell: 9437558720
59.	Sri Susanta Kumar Dakua	J.S.C.A	C/oS.C.R.O.–CUM–WDTL, Dashmantpur At/Po:Podagada Dist: Koraput Cell: 9438376648
60.	Sri Bijya Kumar Mishra	J.S.C.A	C/oS.C.R.O.–CUM–WDTL, Kundra At/Po:Kundra Dist: Koraput Cell: 9438164950
61.	Sri Upendra Kumar Tripathy	J.S.C.A	C/oS.C.R.O.–CUM–WDTL, Dashmantpur At/Po:Podagada Dist: Koraput Cell: 9338454973
62.	Sri Chitrasen Pradhan	J.S.C.A	C/oS.C.R.O.–CUM–WDTL, Dashmantpur At/Po:Podagada Dist: Koraput ☎ 06852-258533
63.	Sri Soraj Kumar Rath	J.S.C.A	O/o Asst. Soil Conservation Officer Po/Dist:Koraput (Orissa) Pin:764 020 Cell: 9438345882
65.	Sri Gouri Sankar Panda	J.S.C.A	C/o SCRO, Borigumma At/Po:Borigumma Dist: Koraput Cell: 9437373701
66.	Sri Surendranath Swain	J.S.C.A	O/o SCRO-Cum-WDTL Po/ Kotpad Pin:764 020 Cell: 9937448873
67.	Sri M. Benu Gopal	Amin	O/o Asst. Soil Conservation Officer Po/Dist:Koraput (Orissa) Pin:764 020 ☎ 06852-250114 Cell: 9938934861
68.	Sri P. Srinivas Rao	Amin	O/o Asst. Soil Conservation Officer Po/Dist:Koraput (Orissa) Pin:764 020 ☎ 06852-250114
69.	Sri Ghanasyama Barik	Komadar	O/o Asst. Soil Conservation Officer Po/Dist:Koraput (Orissa) Pin:764 020 ☎ 06852-250114

70.	Sri Narayana Mallick	Komadar	C/oS.C.R.O., Pottangi At/Po:Pottangi Dist: Koraput ☎ 06853-252718
71.	Sri Mangalu Moharana	Komadar	C/oS.C.R.O.-CUM-WDTL, Narayanpatna At/Po:Narayanpatna Dist: Koraput
72.	Sri Sadasiva Tripathy	Plantation Guard	C/oS.C.R.O., Koraput At/Po:Koraput Dist: Koraput
73.	Sri Satyabadi Jena	Plantation Guard	C/oS.C.R.O.-CUM-WDTL, Kundra At/ Po:Kundra Dist:- Koraput
74.	Sri D. Krishan Murty	Bhumi Rakhyak	O/o Soil Conservation Officer, Koraput
75.	Nandini Panda	Bhumi Rakhyak	O/o Asst. Soil Conservation Officer Po/Dist:Koraput (Orissa) Pin:764 020 ☎ 06852-250114
76.	Sri Bharat Kumar Satapathy	Peon	O/o Asst. Soil Conservation Officer Po/Dist:Koraput (Orissa) Pin:764 020 ☎ 06852-250114
77.	Hemalata Sahu	Peon	O/o Asst. Soil Conservation Officer Po/Dist: Koraput (Orissa) Pin:764 020 ☎ 06852-250114
78.	P. Rina Dora	Peon	O/o Asst. Soil Conservation Officer Po/Dist: Koraput Pin:764 020 ☎ 06852-250114
79.	Sri Guntha Somara	Peon	O/o Asst. Soil Conservation Officer Po/Dist: Koraput (Orissa) Pin:764 020 ☎ 06852-250114
80.	Sri Nilakanth Pattnaik	Driver	O/o Asst. Soil Conservation Officer Po/Dist:Koraput (Orissa) Pin:764 020 ☎ 06852-250297
81.	Sri Parsuram Patro	Sweeper	Deputed at ASCO, Machkund
82.	Sri Mohan Patro Kuldip	Chowkidar	O/o Asst. Soil Conservation Officer Po/Dist: Koraput (Orissa) Pin:764 020 ☎ 06852-250114

POINT – X

The Monthly remuneration received by each of its Officers and Employees including the system of compensation as provided in its regulations.

Sl. No.	Employees Name	Designation	Gross Salary	Monthly
01.	Sri Dayanidhi Bagh	A.S.C.O.	24055	
02.	Sri Sashi Bhusan Pani (Under Suspension)	A.S.C.O	0	
03.	Sri Nani Gopal Rana	Head Clerk	18578	
04.	Sri Jagannath Mishra	Sr. Clerk	16572	
06.	Sri Surendra Nath Swain	Jr. Clerk	11946	
07.	Sri Niradananda Patro	Jr.Clerk	11508	
08.	Sri Kumuda Chandra Patro	J.S.C.O	24102	
09.	Sri Rabindra Kumar Sahu	J.S.C.O	23153	
10.	Sri K.Dasarathi Ram	J.S.C.O.	22724	
11.	Sri Rameswar Majhi	J.S.C.O	10302	
12.	Sri Madhab Chandra Das	S.C.Asst.	20328	
13.	Sri Minaketan Oram	S.C. Asst.	19736	
14.	Sri Subash Chandra Prusty	S.C. Asst.	20328	
16.	Sri Jayasen Murmu	Jr. Engineer	22352	
17.	Sri Harihara Sahu	S.C. Tech. Asst	15950	
18.	Sri Bipini Bihari Panda	S.C Tech. Asst	17640	
19.	Sri Arjuna Bhatra	S.C. S.O.	14254	
20.	Sri Udayanatha Mahankuda	S.C. S.O.	12702	
21.	Sri Purusottam Mohanto	S.C. S.O.	15488	
22.	Sri Satish Pattnaik	S.C. S.O.	14980	
23.	Sri Siba Ram Sahu	S.C. S.O.	13250	
24.	Sri Panchanan Moharana	S.C. S.O.	0	
25.	Sri Durjyadhana Sahu	S.C. S.O.	8654	
26.	Sri Khirabdhi Singh	S.C. S.O.	13096	
27.	Sri Purna Chandra Nayak	S.C. S.O.	13250	
28.	Sri Ram Prasad Shroff	S.C. S.O.	13275	
30.	Sri Rabindra Kumar Mallick	S.C. S.O	13250	
31.	Sri Laxmi Kanta Behera	S.C. S.O	14484	
33.	Sri Prasant Kumar Patro	S.C. S.O	15748	
34.	Sri Ramesh Chandra Sahoo	S.C. S.O	13665	
35.	Sri Narendronath Naik	S.C. S.O	14980	
36.	Sri Surendra Behera	J.S.C.A	13250	
37.	Sri Nityananda Pothal	J.S.C.A	13250	
38.	Sri Kailash Chandra Patro	J.S.C.A	13250	
39.	Sri Bidya Dhara Dash	J.S.C.A	13250	
40.	Sri Rajendra Kumar Bal	J.S.C.A	12702	
41.	Sri Manoj Kumar Panda	J.S.C.A	11871	
42.	Sri Gangadhar Behera	J.S.C.A	12702	
43.	Sri Jayarama Rout	J.S.C.A	13250	
44.	Sri Shyam Narayan Ram	J.S.C.A	13250	
45.	Sri Pradeep Kumar Lima	J.S.C.A	11701	
46.	Sri Ganapati Sethi	J.S.C.A	13250	
47.	Sri B.Dileswar Rao	J.S.C.A	12702	
48.	Sri Bighnaraj Jena	J.S.C.A	12505	
49.	Sri Raj Kishore Bisoyi	J.S.C.A	13583	
50.	Sri Narayan Chandra Majhi	J.S.C.A	13250	
51.	Sri Hemanta Ku. Satpathy	J.S.C.A	12427	

52.	Sri B. Nageswar Rao	J.S.C.A	11410
53.	Sri Hadubandhu Sabar	J.S.C.A	11024
54.	Sri Rajendra Mohanty	J.S.C.A	12632
55.	Sri Jaya Tangu	J.S.C.A	12652
56.	Sri Brundaban Mohankuda	J.S.C.A	11024
57.	Sri Sameer Kumar Pradhan	J.S.C.A	11871
58.	Sri Dilip Kumar Padhi	J.S.C.A	12076
59.	Sri Madhu Hontal	J.S.C.A	12361
60.	Sri Jagannath Tripathy	J.S.C.A	11380
61.	Smt. Lilimani Singh	J.S.C.A	11871
62.	Sri Surendra Nath Panda	J.S.C.A	13250
63.	Sri Susanta Kumar Dakua	J.S.C.A	11701
66	Sri Bijya Kumar Mishra	J.S.C.A	12871
67.	Sri Upendra Kumar Tripathy	J.S.C.A	12632
68	Sri Chitrasen Pradhan	J.S.C.A	11024
69.	Sri Soraj Kumar Rath	J.S.C.A	11710
70.	Sri Gouri Sankar Panda	J.S.C.A	11513
71.	Sri Kailash Ch Rath	J.S.C.A	8555
72.	Sri Prasanta Ku, Swain	J.S.C.A	11483
73.	Sri M. Benu Gopal	Amin	10721
74.	Sri P. Srinivas Rao	Amin	10440
75.	Sri Ghanasyama Barik	Komadar	9222
76.	Sri Narayana Mallick	Komadar	9777
79.	Sri Mangalu Moharana	Komadar	9620
80.	Sri Sadasiva Tripathy	Plantation Guard	9620
82.	Sri Satyabadi Jena	Plantation Guard	9620
83	Sri D. Krishan Murty	Bhumi Rakhyak	9222
84	Nandini Panda	Bhumi Rakhyak	8514
85	Sri Bharat Kumar Satapathy	Peon	9620
86	Hemalata Sahu	Peon	9620
87	P. Rina Dora	Peon	9083
88	Sri Guntha Samara	Peon	9222
89	Sri Mohan Patro Kuldip	Choukidar	9620
90	Sri Parsuram Patra	Sweeper	8514
91	Sri Nilakanta Pattnaik	Driver	11739

Sl. No.	Name of the Scheme	Budget Provision	Amount Sanction	Expenditure incurred up To 12/2006 (Provisional Departmental)
01	Dist. Administration (Non Plan)	4125582 /-	4159436 /-	2937700 /-
02.	Head quarters Organization (Non Plan)	642608 /-	653893 /-	458610 /-
03.	Soil Survey Organization (Non Plan)	862591 /-	857339 /-	615805 /-
04.	Watershed Management Unit (Non Plan)	988667 /-	1039558 /-	786580 /-
05.	Prevention Podu Cultivation (Non Plan)	783484 /-	874922 /-	625293 /-
06.	Festival Advance	96000 /-	96000 /-	96000 /-
07.	S.C.D.C. (Non Plan)	155559 /-	155191 /-	110070 /-
08.	Water shed development (Non Plan)	477406 /-	474770 /-	336850 /-
09.	Sisal (Non Plan)	67577 /-	67944 /-	277122 /-
10.	S.C. Training (Non Plan)	166434 /-	166424 /-	128640 /-
11.	C.B.Land (Non Plan)	--	--	--
12.	Machkund Catchment (Non Plan)	137662 /-	137531 /-	150827 /-

POINT – XI

The Budget allocated to each of its agency Indicating the particulars of all plans, proposed expenditure and reports on disbursements made:

POINT – XII

The manner of execution of subsidy programmes, including the amounts allocated and the details of beneficiaries of such programmes.

*** Not applicable to Directorate of Soil conservation ***

POINT – XIII

**Particulars of recipients of
concessions, permits or
authorizations grant by it.**

*** Not applicable to Directorate of Soil conservation ***

POINT – XIV

Details in respect of the information, available to or held by it, reduced in an electronic form.

*** Not applicable to Directorate of Soil conservation ***

POINT – XV

The Particulars of facilities available to citizens for obtaining information, including the working hours of a library or reading room, if maintained for public use.

*** Not applicable to Directorate of Soil conservation ***

POINT – XVI

The names, designations and other particulars of the public information officers.

Name of the Authority – Sri Dayanidhi Bag Msc. (Ag)
Asst. Soil Conservation Officer,
Koraput

E. Mail - asco-koraput@yao.co.in

The Name and Designation of Information Officers are as follows:

Sl. No.	Name	Designation		STD Code	Phone	Fax	Address
01.	Sri Dayanidhi Bag	ASCO	First Appellate Authority	06852	06852 250114 Cell: 9437624982	06852 250114	Asst. Soil Conservation Officer, Koraput
02.	Sri Nani Gopal Rana	Head Clerk	Public Information Officer	06852	06852 250114 Cell: 9938934523	06852 250114	
03.	Sri B. Dileswar Rao	JSCA	Asst. Public Information Officer	06852	06852 250114 Cell: 9937267455	06852 250114	

POINT – XVII

Such Other information as may be prescribed and thereafter updated these publication every year.

*** Not applicable to Directorate of Soil conservation ***